

EC300 DT145

DRILLRIG

Total weight 42 ton
Mast weight 6.500 kg
Mast total length 8.500-15.500 mm
Crowd force 140kN

SPD

SCANDINAVIAN PILE DRIVING AB



DT145.EC300

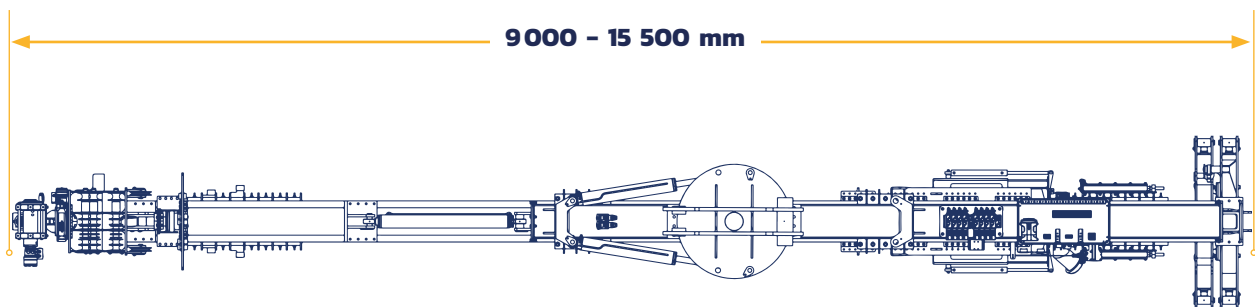
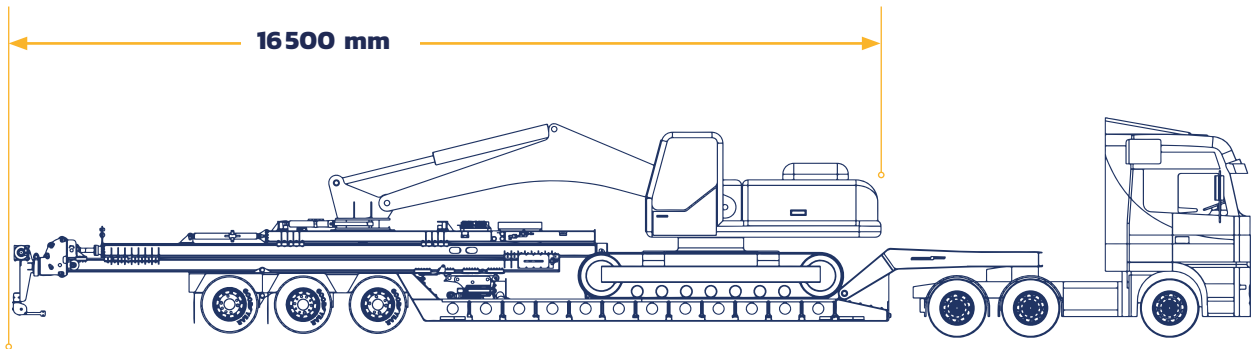

Technical specifications mast

Telescopic mast

Mast weight without rotary	6.500 kg
Mast total length	8.500 mm - 15.500 mm
Recommended carrier	30 - 36 ton
Mast stroke	13.000 mm
Side tilting	+/- 15 grader (cylindrar)
Oil need with RH1200	> 150 lit/min @ 200 bar
Crowd force	140kN
Feeding by ropes	
Feeding speed	0 - 0,4 m/s
Feeding beam in steel	
Remote control SPD with Can bus	

Clamping table

Opening	410 mm
Min. clamp diameter	45 mm
Max. clamp diameter	410 mm
Break out force	5.000 daNm

Service winch

Model	Sepson H60P 2.000 daN
-------	-----------------------

Standard Top hammer

Model	Eurodrill HD4010
Weight	435 kg
Rotation speed (97)	110 Rpm@150lit/min
Torque (97)	4,35 kNm @ 200 bar @ 85 lit/min
Energy	500 Nm
Frequency	2.400 bpm
Shank adaptors	R32, R38, R51 & T45, H55, H64, C64LH/RH

Standard Rotary

Model	Eurodrill RH1200
Weight	310 kg
Rotation speed (31)	68 rpm@150lit/min
Torque (31)	14,1 kNm vid 200 bar @150 lit/min
Std Thread	3 1/2" API Reg Female
Swivel passage	2"

Functional and flexible

- » Powerful 15 degree tilt.
- » Remote control makes it easy to operate the machine with full control.
- » Modular – quick coupling between the mast and excavator as well as the feed cradle
- » Top winch with 180 degree rotation

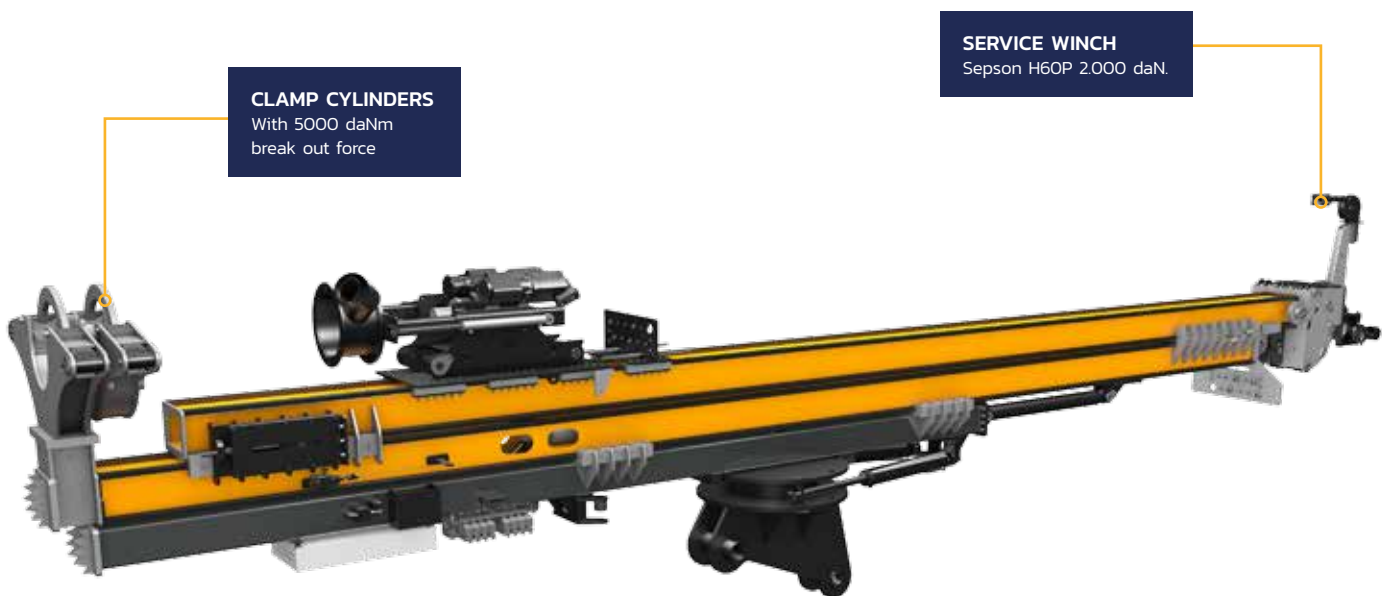

Purpose of use

- Foundation drilling
- CFA
- Top hammer drilling

DT145.EC300

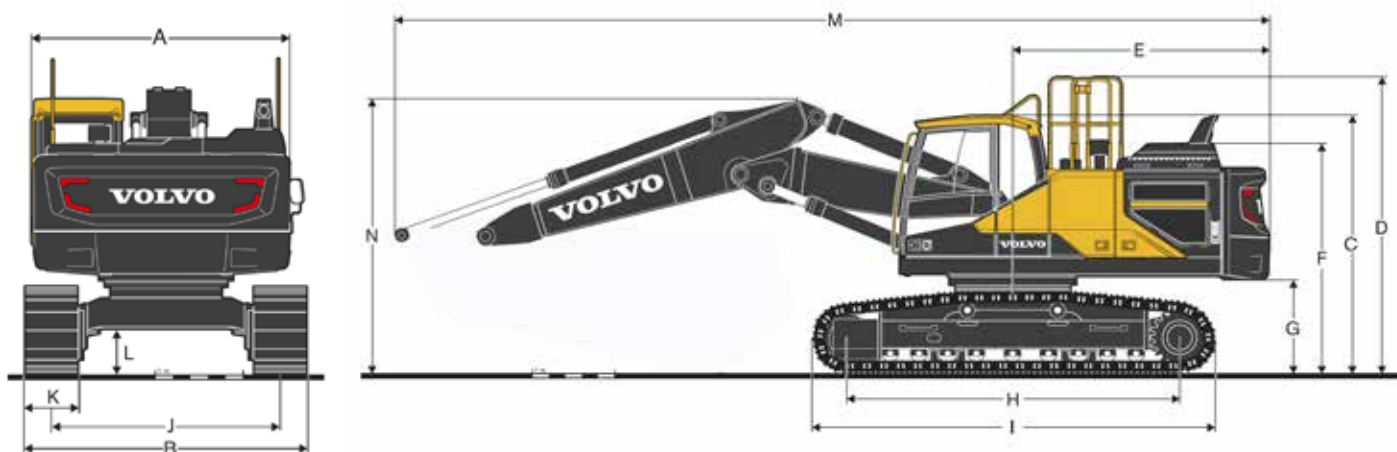

Technical specifications Volvo

Volvo EC300ENL

Machine total weight with mast	42.000 kg
Standard counter weight	5 500 kg
Extra counter weight	3 000 kg
Machine width (B)	3 090 mm
Machine height (D)	3 600 mm
Machine transport length with mast	16 500 mm
Motor	Steg IV (4)
Motor power, netto	179 kW / 243 hk
Mast connection	in the boom of excavator
Boom	2 piece
Shaft	No shaft
Remote control SPD with Can bus	

Under carriage

Width (B)	3 090 mm
Crawler plate width	700 mm
Plate HD, bottom of undercarriage	10 mm

Greasing

Automatic greasing

Motor

Dieselmotor EU step IV (4)

Engine heater

Waterseparating filter Tripple R

Cooling fan, standard

Cooling standard + 40 grader

Cabin

ROPS - Care Cab with roof window

ECC climat system

Radio with MP3, USB and bluetooth

Camera, backward and to the right side

Care Track

Hydraulic

X1 and X3 hydraulics

Stability diagram

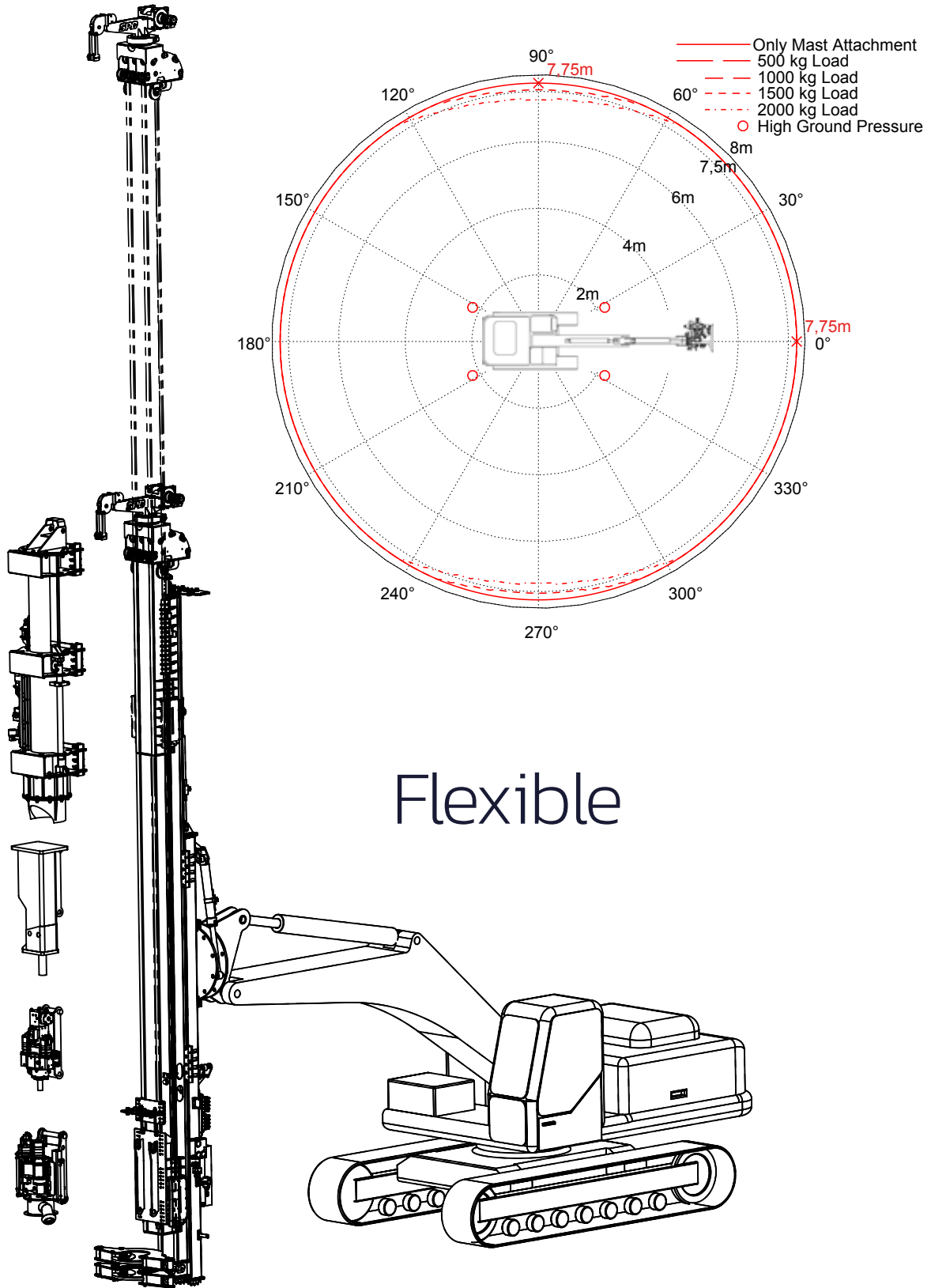

Flexible







**Fridhemsgatan 16
733 39 Sala, SWEDEN
Org.nr: 556653-4565**

**+46 (0)224-138 10
info@spd.se
www.spd.se**