

DM55.2

DRILL RIG MAST

Mast weight 4,500 kg
Total mast length 6,800 mm
Recommended excavators 16-30 ton
Feed force 100 kN

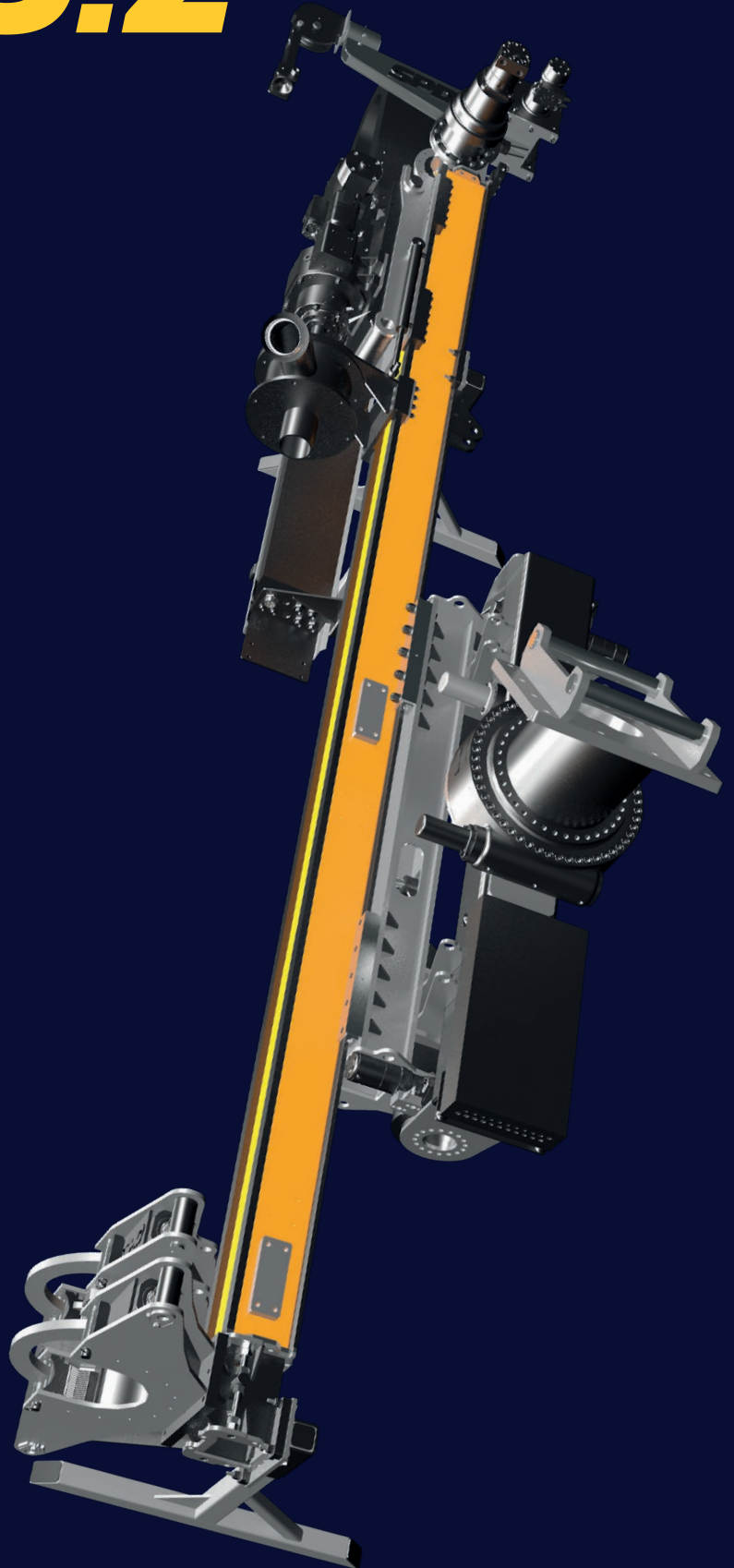

SPD
SCANDINAVIAN PILE DRIVING AB

DM55.2

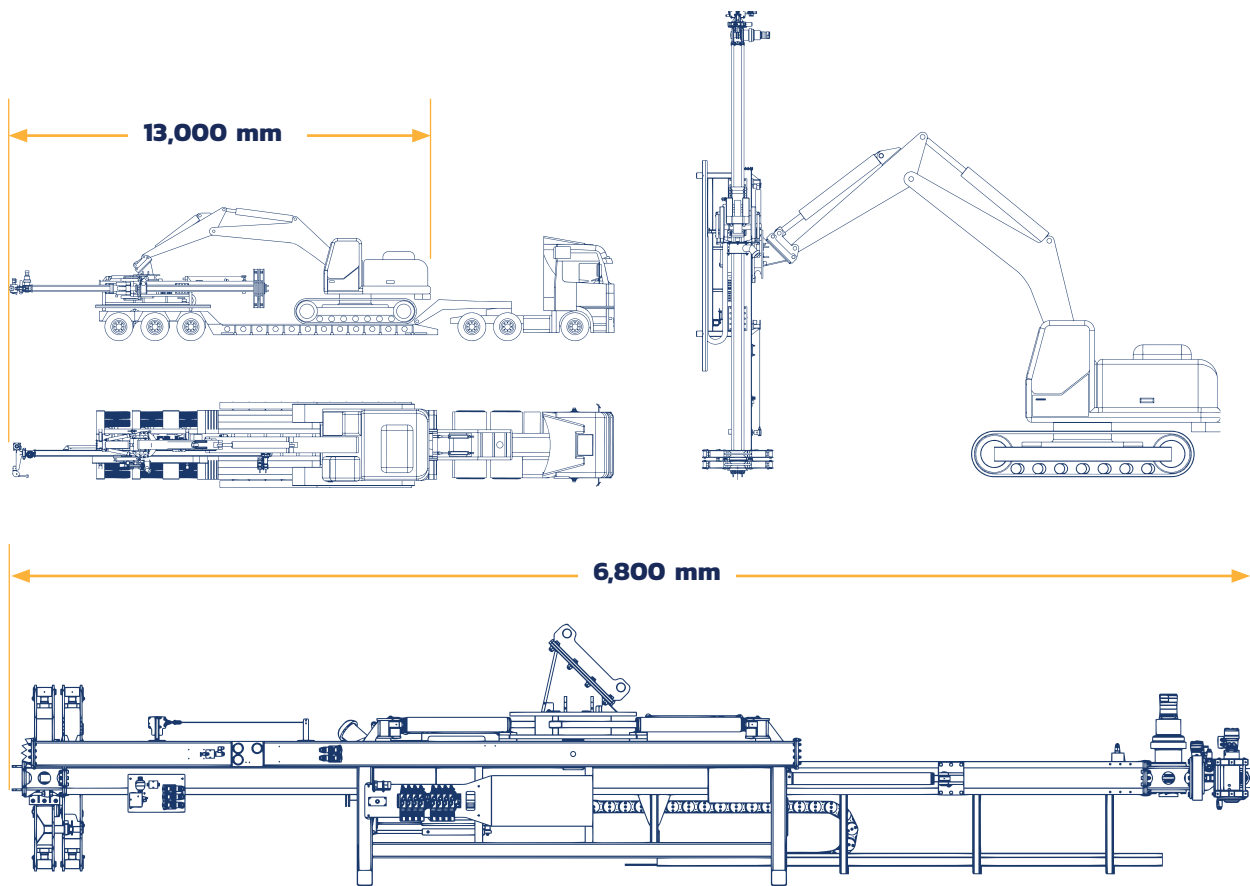

Technical specifications

Drill Rig Mast

Mast weight	4,500 kg
Total mast length	6,800 mm
Recommended excavators	16 -30 ton
Mast stroke length	4,000 mm
Lateral tilt	360°
Oil need with HD4010	> 245 L/min @ 200 bar
Feed force	100 kN
Feed chain	1 1/4"
Feed speed	0-0.4 m/s
Feed beam in steel	
Remote control from SPD with Can bus	

Clamping table

Opening	350 mm
Min. clamp diameter	45 mm
Max. clamp diameter	350 mm
Break out cylinder power	5,000 daNm

Service winch

Model	Sepson H60P 2,000 daN
-------	-----------------------

Standard top hammer

Model	Eurodrill HD4010
Weight	435 kg
Rotary speed (97)	110 rpm@150 L/min
Torque (97)	4.35 kNm at 200 bar @85 L/min
Strike power	500 Nm
Frequency	2,400 bpm
Shank adapter	R32, R38, R51 &T45, H55, H64, C64LH/RH

Standard rotation

Model	Eurodrill RH1200
Weight	310 kg
Rotational speed (31)	68 rpm@150 L/min
Torque (31)	14.1 kNm at 200 bar @150 L/min
Std. thread	3 1/2" API Reg. Female
Swivel passage	2"

All technical data can be changed without notification.

Remote controlled and flexible

- » Multipurpose-mast.
- » Remote control makes it easy to operate the machine with full control.
- » Quick coupling between the mast and excavator, as well as the feed cradle.
- » Modular and strong construction.

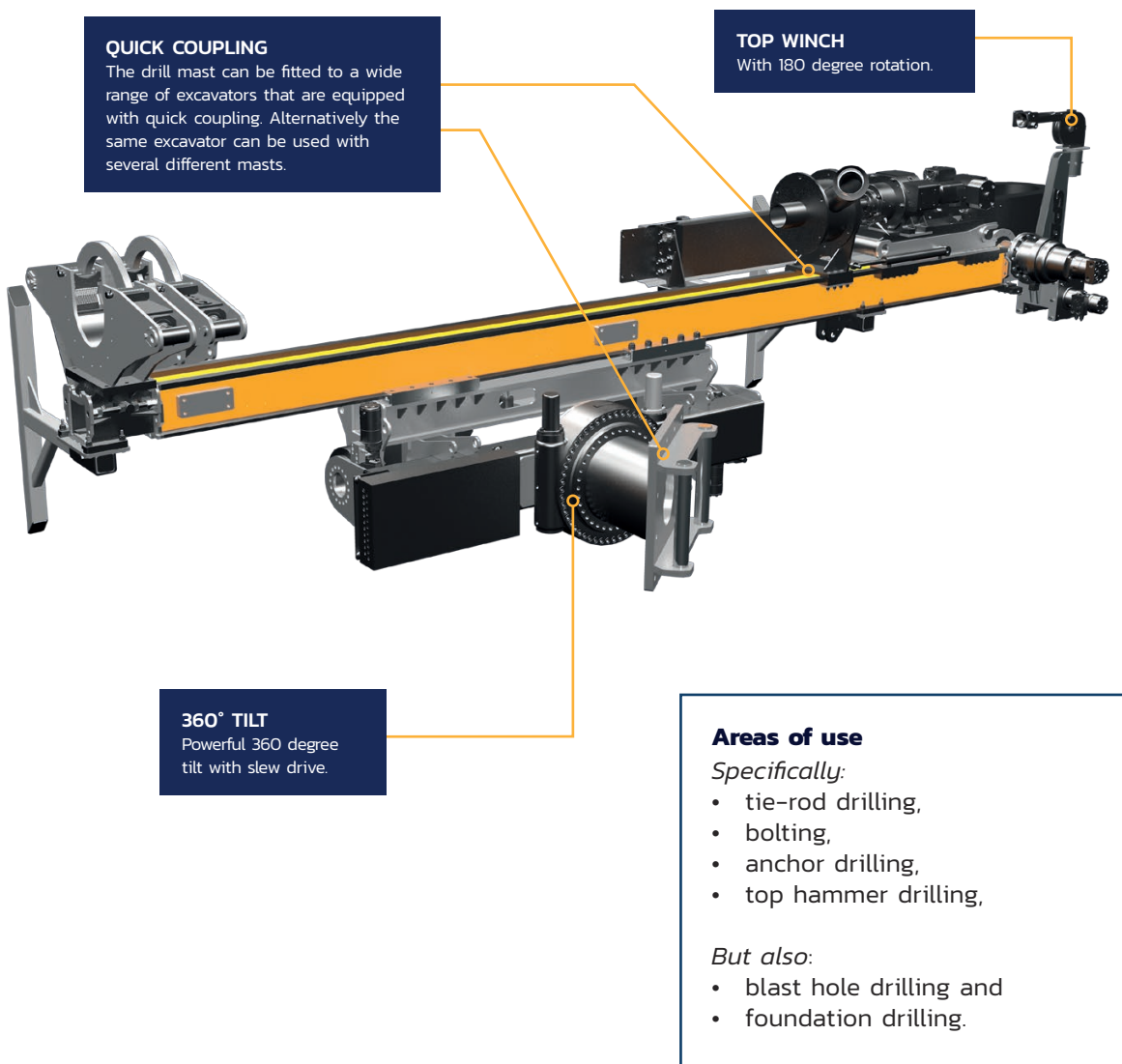



**Fridhemsgatan 16
733 39 Sala, SWEDEN
Org.nr: 556653-4565**

**+46 (0)224-138 10
info@spd.se
www.spd.se**